

PERFORMANCE DATA SHEET NEMA PREMIUM NR CAN NEMA 12 - 12

Catalogue #: **MPOP-71**

HP	kW	Voltage	S.F. @ 60Hz	EFF.	P.F.	Frame	Design	L.R. Amps
75	55,95	575	1,15	93,6%	0,9	364TS	B	434

60 Hz								Code	F.L. RPM
FLA									
208	230	416	460	480	575	600		G	3565
/	/	/	/	/	67	64,20			

50 Hz								Code	F.L. RPM
FLA			S.F. @ 50Hz	Efficiency	Power Factor				
190	380	415				/	/	/	/
/	/	/							

Wgt. Lbs	PH	Duty	Insul. Class	Amb.	Elevation	Temp. Rise° C
766	3	Cont.	F	40°C	1000M (3300 Ft)	< 80

% Efficiency		% Power Factor		Torque		Winding Resist. Ω	Safe Cold Start (Secs)
Full Load:	93,6%	Full Load:	0,90	Full Load Ft/Lbs	110,5		
3/4 Load:	93,0%	3/4 Load:	0,88	Locked Rotor %	190		
1/2 Load:	92,5%	1/2 Load:	0,83	Break Down %	250		

Rotor Inertia Wk2 Lb-Ft2	Max Load Inertia Wk2 Lb-Ft2	Shaft Material	Frame Material	DE Bracket Type	ODE Bracket Type	Enclosure	NEMA Rating	Lead Wire Size
6,64	97	Standard	Cast Iron	Standard	Standard	ODP	IP23	7AWG

Ball Bearings		Grease	Mount Type	Orientation	Paint	Sound Pressure @ 3FT	Sound Power
DE	ODE						
6313	6313	Mobil PolyrexEm	Rigid	Horizontal	Green	90	101

Inverter Duty. Motor meets MG1 parts 31.4.4.2	Constant Torque Range	Variable Torque Range	Constant HP RPM
		10:1	20:1

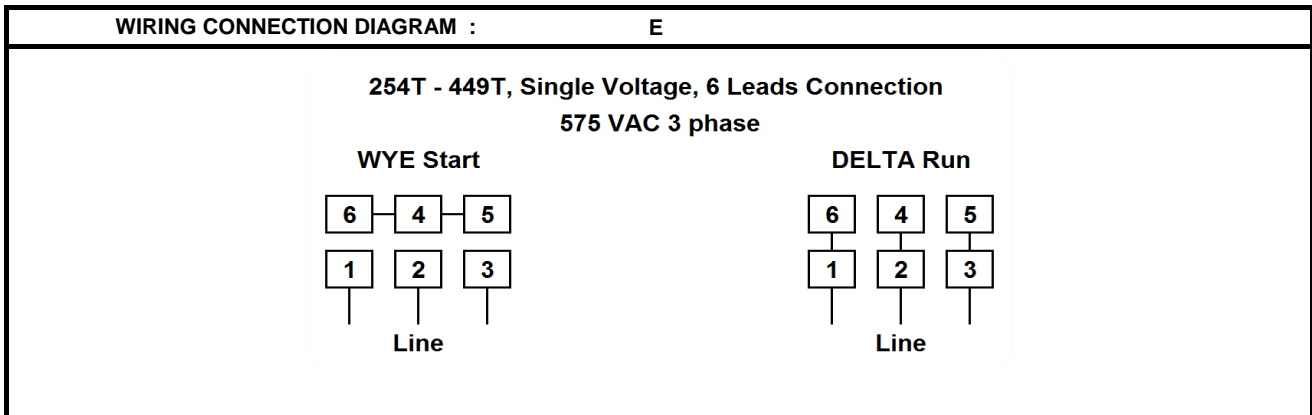

Date: 2020-02-25
 Customer: _____
 Contact: _____
 Submittee: J.C. Lavallée

Catalogue #: **MPOP-71**

NEMA PREMIUM NR CAN NEMA 12 - 12										
HP	VAC	RPM	Enclosure	Frame	Frequency	Design	Poles	LR Code Letter	Insulation Class	Temp. Rise °C
75	575	3565	ODP	364TS	60	B	2	G	F	< 80
	0Hz	6Hz	15Hz	30Hz	45Hz	60Hz	75Hz	90Hz	105Hz	120Hz
Amps	67	67	67	67	67	67	67	67	67	67
RPM	0	356,5	891,25	1782,5	2673,75	3565	4456,25	5347,5	6238,75	7130
Torq ft.lb	88,39	110,49	110,49	110,49	110,49	110,49	88,39	73,66	63,14	55,25
Peak Tq ft.lb	124,30	248,60	248,60	248,60	248,60	248,60	198,88	165,74	142,06	124,30
HP	0	7,5	18,8	37,5	56,3	75,0	75,0	75,0	75,0	75,0
	Locked Rotor	Pull-Up	Breakdown	Rated Load	Idle	Duty	S. F.	Ambient	Elevation	dBA @ 1M
Speed (RPM)	0,0	1512	2880	3565	3600	Continuous	1,15	40°C	3300 ft	90
Current (Amps)	434,0	368,9	258,2	67,0	16,8	VFD Rating: Meets MG1 parts 31.4.4.2				
Torque (ft-lbs)	209,9	157,4	276,2	110,5	0,0	C.T.	10:1	V.T.	20:1	

Motor Speed Data

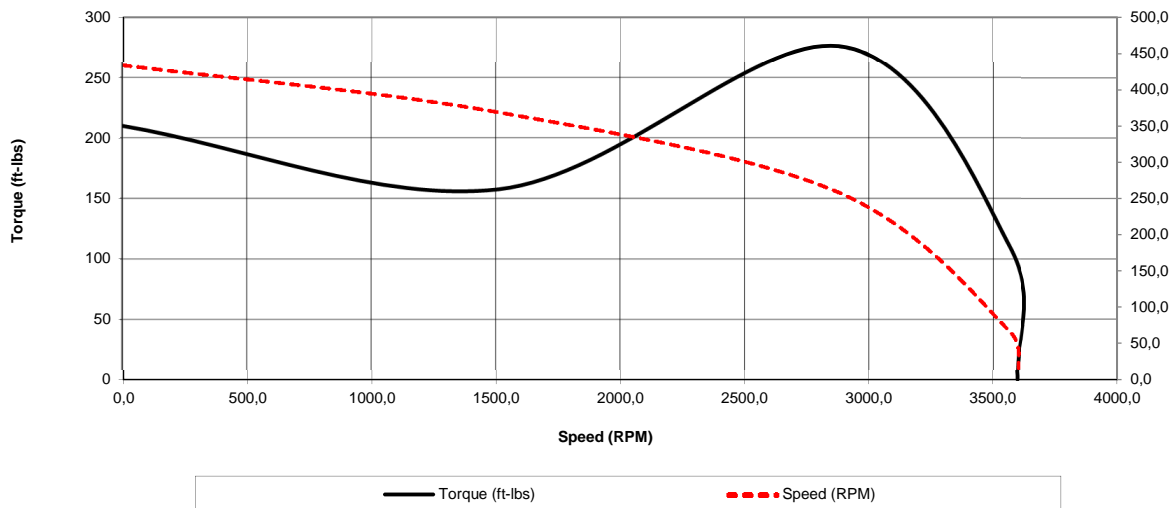

Motor Torque Capability vs RPM

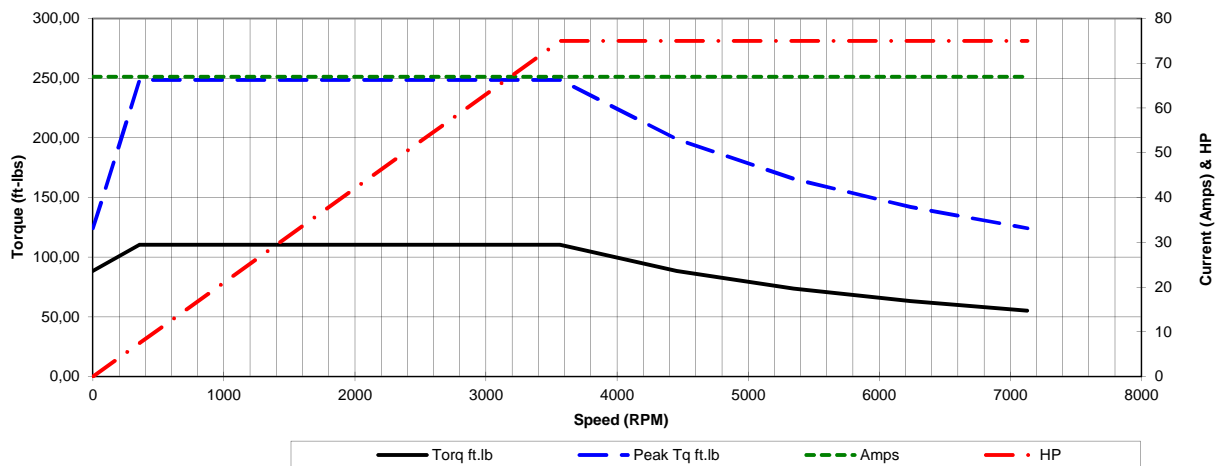



Date: 2020-02-25
 Customer: _____
 Contact: _____
 Submittee: J.C. Lavallée

Catalogue #: **MPOP-71**

NEMA PREMIUM NR CAN NEMA 12 - 12										
HP	VAC	RPM	Enclosure	Frame	Frequency	Design	Poles	LR Code Letter	Insulation Class	Temp. Rise °C
75	575	3565	ODP	364TS	60	B	2	G	F	< 80
Load %	0%	25%	50%	75%	100%	125%	150%			
Amps	16,82	23,95	36,78	51,26	67,00	83,36	101,50			
Torq ft/lbs	0	27,42	54,98	82,67	110,49	138,45	166,55			
RPM	0	3591,25	3582,5	3573,75	3565	3556,25	3547,5			
Eff	0	80,11	92,50	93,00	93,60	93,60	93,60			
PF	0	73,2	83	88	90	90	88,7			
	Locked Rotor	Pull-Up	Breakdown	Rated Load	Idle	Duty	S. F.	Ambient	Elevation	dBA @ 1M
Speed (RPM)	0	1512	2880	3565	3600	Continuous	1,15	40°C	3300 ft	90
Current (Amps)	434	368,9	258,2	67	16,817	VFD Rating: Meets MG1 parts 31.4.4.2				
Torque (ft-lbs)	209,93	157,45	276,23	110,49	0,0	C.T.	10:1	V.T.	20:1	

